



RECESSED DOOR TO RECEIVE DRYWALL

Model RDWPD

WITH FACTORY INSTALLED DRYWALL



KARP ASSOCIATES, INC.
 54-54 43rd Street, Maspeth, NY 11378
 (718) 784-2105 - Phone
 (718) 784-9169 - Fax

DATE

SPECIFICATIONS

GENERAL SCOPE:

Access doors shall be Karp Type RDWPD as manufactured by Karp Associates, Inc., Maspeth, N.Y. Sizes shall be as indicated on the drawings.

CONSTRUCTION:

1. Frame shall be 14 gage steel and doors shall be 16 gage steel.
2. Door shall be recessed 1/2" with factory install 1/2" drywall.
3. Trim shall be galvanized steel dry wall bead.
4. Hinge shall be concealed pivoting rod type.
5. Locks shall be flush and screwdriver operated with stainless steel cam and studs, or shall be key operated cylinder lock with automatic dust shutter.
6. Finish shall be prime coat of rust inhibitive electrostatic powder, baked grey coat.

STANDARD SIZES

DOOR SIZE H X W (IN.)	WALL/CEILING OPENING (IN.)	NUMBER OF LATCHES	SHIP WT. (LBS.)
12 x 12	12 1/8 x 12 1/8	1	8
18 x 18	18 1/8 x 18 1/8	2	15
24 x 12	24 1/8 x 12 1/8	2	14.5
24 x 24	24 1/8 x 24 1/8	4	24.5
36 x 24	36 1/8 x 24 1/8	5	36.5

PROJECT DATA					
Project Name:					
Architect:					
Contractor:					
Agent/Customer Name:					
Tagging Instructions:					
Special Instructions:					

PROJECT SCHEDULE					
Qty.	H	W	No. of Latches	Finish	Remarks

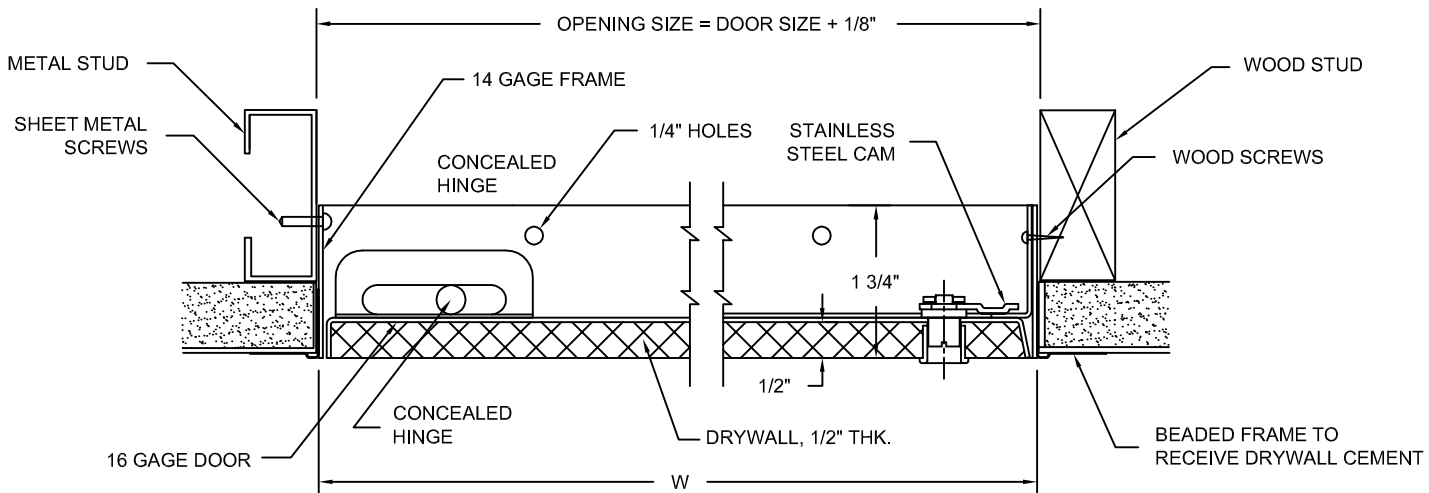
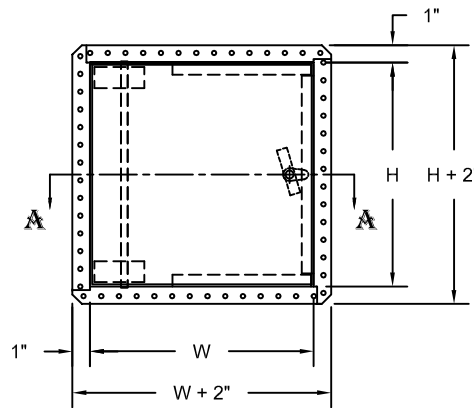

SECTION A-A

