



PRESS-FIT ACCESS DOOR

Model PF

For Coated Steel

DATE



KARP ASSOCIATES, INC.
 260 Spagnoli Road Melville, NY 11747
 (631) 768-8300 - Phone
 (631) 768-8350 - Fax

SPECIFICATIONS

GENERAL SCOPE:

Access doors shall be Karp Type PF as manufactured by Karp Associates, Inc., Melville, N.Y.
 Sizes shall be as indicated on the drawings.

CONSTRUCTION:

1. Trim, return, and door stop shall be one-piece construction of 22 gage steel. On doors 18" x 18" and larger, the door shall be 20 gage steel. On doors smaller than 18" x 18", the door shall be 22 gage steel.
2. Flange of frame shall be 1/2" wide and beveled.
3. Hinge shall be concealed, continuous piano hinge.
4. Latches shall be flush screwdriver operated, or key operated cylinder lock with automatic dust shutter.
5. Return shall have bendable tabs for easy installation into drywall.
6. Finish shall be prime coat of rust inhibitive electrostatic powder, baked white enamel.

STANDARD SIZES

| DOOR SIZE H X W (IN.) | WALL/CEILING OPENING (IN.) | NUMBER OF STUD LATCHES | SHIP WT. (LBS.) |
|--------------------------|-------------------------------|------------------------------|--------------------|
| 8 x 8 | 7 13/16 x 7 13/16 | 1 | 1.5 |
| 12 x 12 | 11 13/16 x 11 13/16 | 1 | 2.5 |
| 14 x 14 | 13 13/16 x 13 13/16 | 2 | 3.0 |
| 18 x 18 | 17 13/16 x 17 13/16 | 2 | 4.6 |
| 24 x 24 | 23 13/16 x 23 13/16 | 3 | 7.4 |

* On sizes 18" x 18" and larger, gage is 20. On sizes smaller than 18" x 18", gage is 22.

| PROJECT DATA | | | | | |
|-----------------------|--|--|--|--|--|
| Project Name: | | | | | |
| Architect: | | | | | |
| Contractor: | | | | | |
| Agent/Customer Name: | | | | | |
| Tagging Instructions: | | | | | |
| Special Instructions: | | | | | |

| PROJECT SCHEDULE | | | | | |
|------------------|---|---|----------------|--------|---------|
| Qty. | H | W | No. of Latches | Finish | Remarks |
| | | | | | |
| | | | | | |
| | | | | | |
| | | | | | |
| | | | | | |
| | | | | | |
| | | | | | |

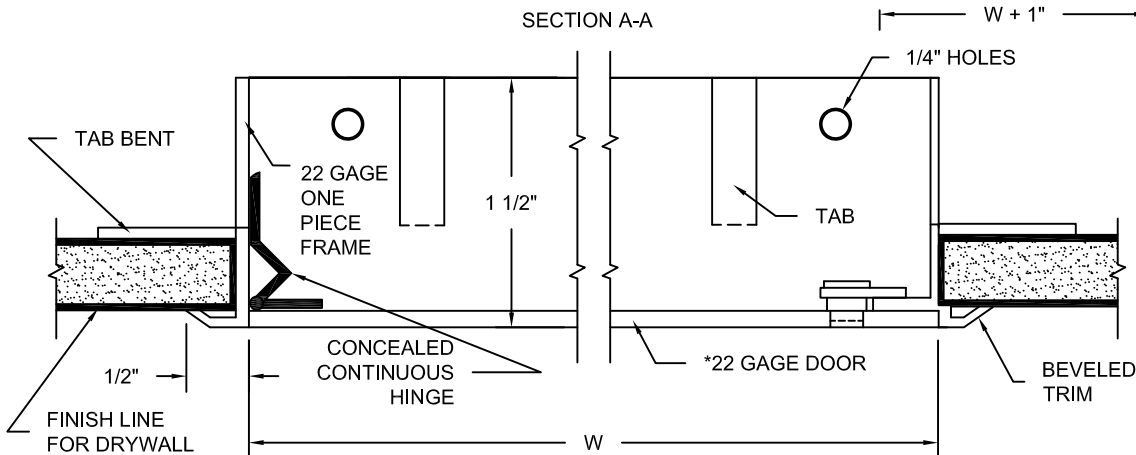
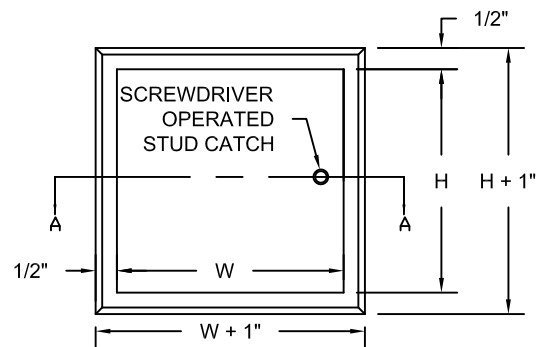

Made with Union Labor