



RECESSED DOOR TO RECEIVE DRYWALL

Model RDWPD w. 2.35" Depth

WITH FACTORY INSTALLED DRYWALL

DATE



KARP ASSOCIATES, INC.
 260 Spagnoli Road Melville, NY 11747
 (631) 768-8300 - Phone
 (631) 768-8350 - Fax

SPECIFICATIONS

GENERAL SCOPE:

Access doors shall be Karp Type RDWPD as manufactured by Karp Associates, Inc., Melville, N.Y. Sizes shall be as indicated on the drawings.

CONSTRUCTION:

1. Frame shall be 16 gauge steel and doors shall be 16 gauge steel.
2. Door shall be recessed 5/8" with factory install 5/8" drywall.
3. Trim shall be galvanized steel dry wall bead.
4. Hinge shall be concealed rod for pivoting door.
5. Locks shall be flush and screwdriver operated with cam and studs, or shall be key operated cylinder lock with automatic dust shutter.
6. Finish shall be prime coat of rust inhibitive electrostatic powder, baked white enamel.

STANDARD SIZES

DOOR SIZE H X W (IN.)	WALL/CEILING OPENING (IN.)	NUMBER OF LATCHES	SHIP WT. (LBS.)
12 x 12	12 1/8 x 12 1/8	1	8
18 x 18	18 1/8 x 18 1/8	2	15
24 x 12	24 1/8 x 12 1/8	2	14.5
24 x 24	24 1/8 x 24 1/8	4	24.5
36 x 24	36 1/8 x 24 1/8	5	36.5

PROJECT DATA					
Project Name:					
Architect:					
Contractor:					
Agent/Customer Name:					
Tagging Instructions:					
Special Instructions:					

PROJECT SCHEDULE					
Qty.	H	W	No. of Latches	Finish	Remarks

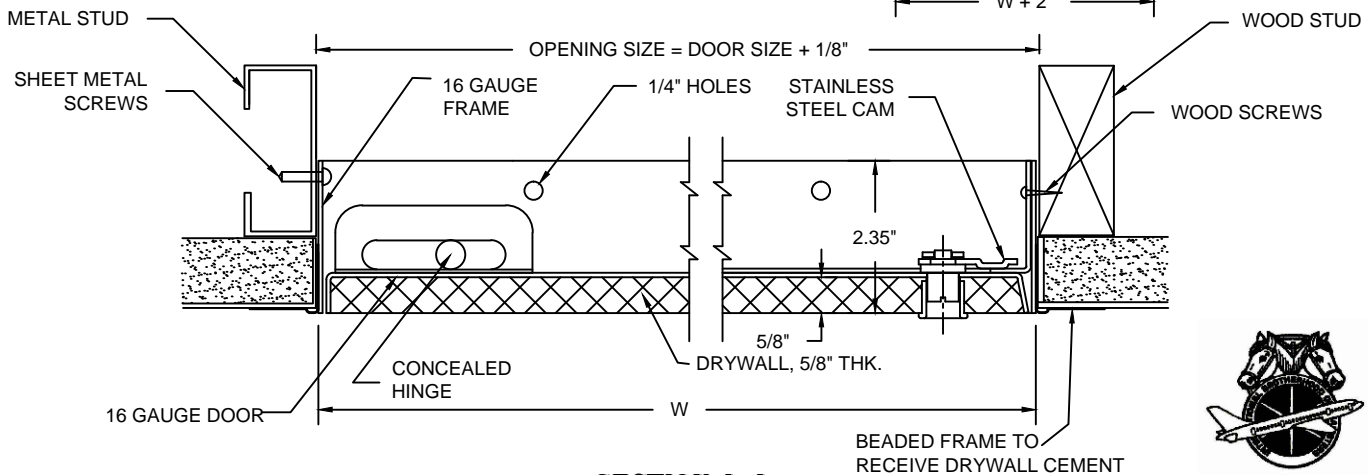
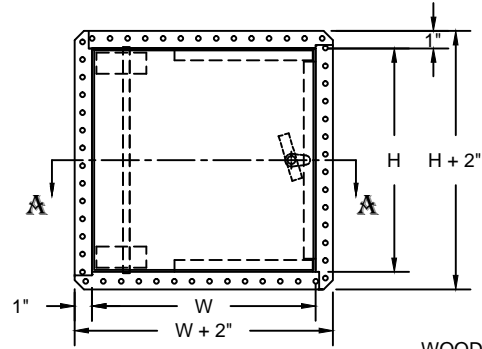

SECTION A-A



Made with Union Labor